



**GENUINE ACCESSORIES
INSTALLATION INSTRUCTIONS**

550-0583 Rev. AAB



PART NUMBER:

0000 8C Z01

APPLICABLE MODELS:

2014 > MAZDA 6

REQUIRED COMPONENTS:

ITEM	QTY	DESCRIPTION	Usage Chart
------	-----	-------------	-------------

MIRROR ASSEMBLY:

1	1	Mirror Assembly w/ Compass	①
---	---	----------------------------	---

INSTALLATION KIT:

2	1	EC Harness - A-Pillar T-Harness	①
3	6	Wire Ties	③
4	1	Wire Cover	①
5	1	A-Pillar Tether Clip (D651-68-162A)	①
6	3	Foam Tape	③
7	1	User Guide	①
8	1	Installation Instructions	①

**Installation kit may have more components than necessary. Please refer to the chart above and the instructions for required components.

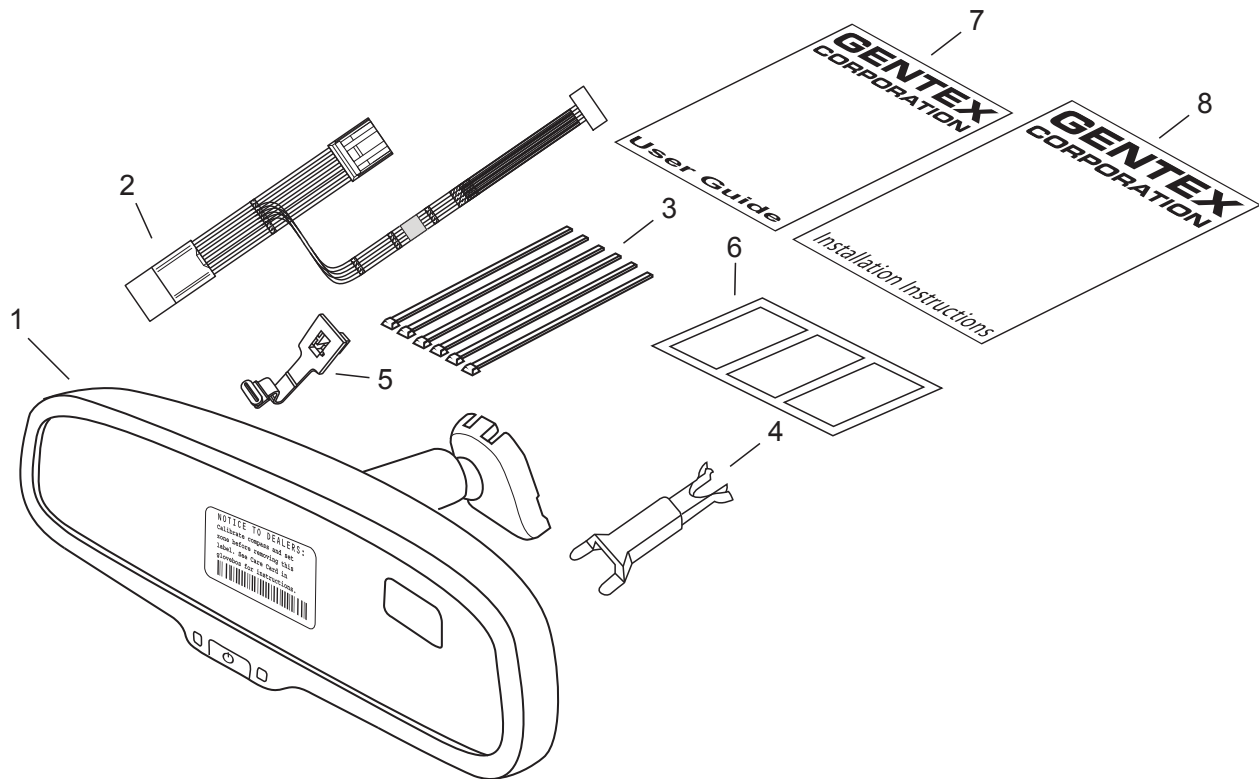

TOOLS REQUIRED:

HOMELINK® AND THE HOMELINK HOUSE® ARE REGISTERED TRADEMARKS OF JOHNSON CONTROLS, INC.

10mm Socket	Ratchet	Fiberstick	Needle Nose Pliers
4mm Flat Screwdriver	#T20 Torx Driver	Torque Wrench	Wire Cutters
Clean Rag			

WIRE CODES

Two-color wires are indicated by a two-letter symbol. The first indicates the base color of the wire, the second indicates the color of the stripe. For example:

W/R = White wire with a red stripe

BR/Y = Brown wire with a yellow stripe

Symbol (Example):

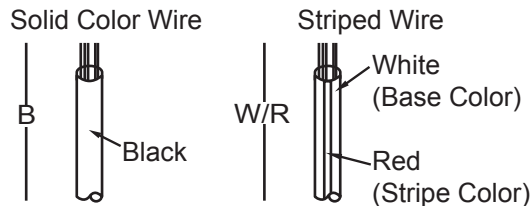

CONNECTOR DIAGRAMS

Connector diagrams show connectors on the harness side. The terminal indicates the view from the harness side.

Example:

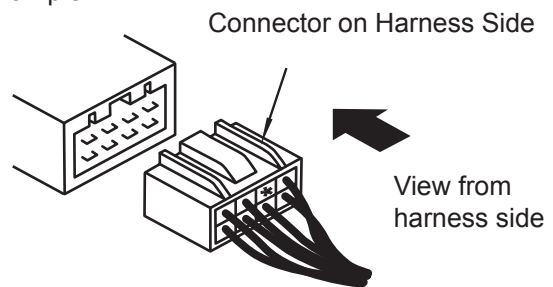

Unused terminals are indicated by "*"

DISCONNECTING CONNECTORS

When disconnecting the wires, grasp the connectors, not the wires.

Example:

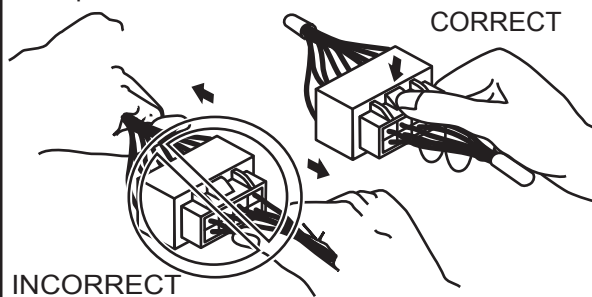

LOCKING CONNECTORS

When locking connectors, listen for a click, indicating they are securely locked.

Example:



WIRE TIE PROCEDURE

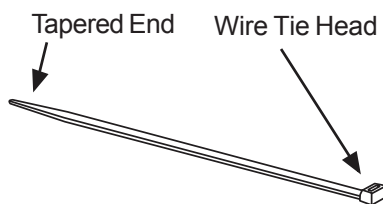

Wrap wire tie around the harness you wish to secure together.

Insert the Tapered End of the wire tie into the Wire Tie Head.

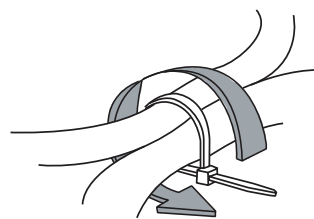

Pull the Tapered End through the Wire Tie Head until the wire tie is snug.

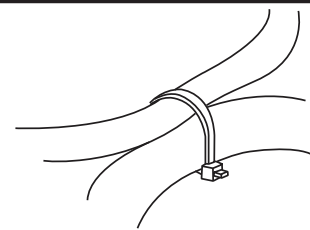

Trim wire tie end after tightening.

IDC WIRE TAP PROCEDURE

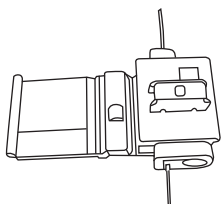

Place IDC on Vehicle Wire.

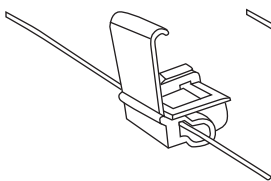

Close side of IDC.

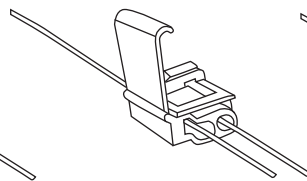

Insert EC Mirror Harness wire into IDC.

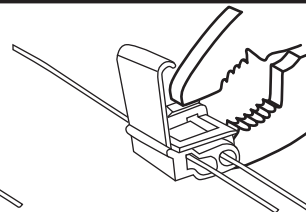

Crimp IDC metal tab over both wires until flush with top of IDC.

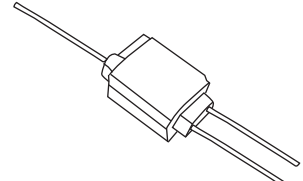

Close top of IDC.

INSTALLATION PRECAUTIONS / NOTES:

- If using fish wire, use caution to avoid damage to existing components.
- Do not place wire harness against objects with sharp edges that may cause electrical shorting.
- Verify that power harness path will not interfere with brake, clutch, emergency brake or air bag operation. Use wire ties to hold the wiring away from critical locations.

1 Preparation

1. Place kit components on a clean, padded surface, and inspect for damage, defects, or missing components.
2. Record customer's programmed Radio - AM/FM/SAT stations and trip computer (if applicable).
3. Disconnect negative battery terminal.
 - a) Remove relay cover and then remove battery cover in order to gain access to battery terminals.
 - b) Using 10mm socket, remove negative battery terminal. (Fig. 1-1)

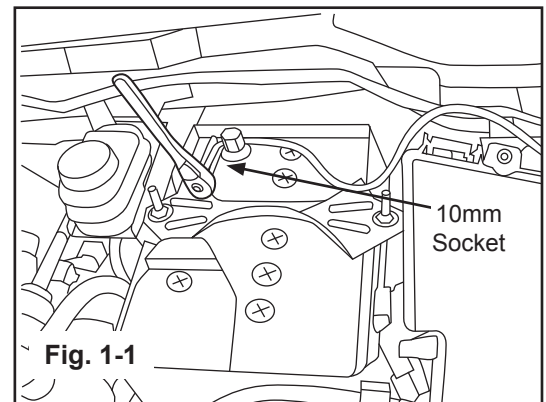

4. Remove driver-side door seal.
 - a) Pull back past top of A-pillar trim. (Fig. 1-2)

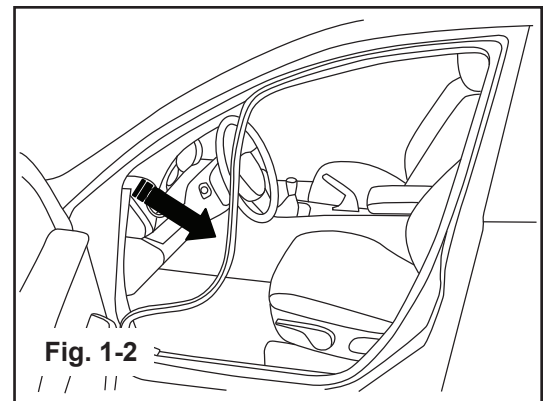

5. Remove driver-side A-pillar trim.
 - a) Pull out the top portion of A-pillar trim towards passenger-side of vehicle until A-pillar connector is extended approximately 1/2".

NOTE



Do not use excessive force. A-pillar could be damaged.

- b) Use needle nose pliers to grasp tab of A-pillar connector. Rotate tab 90 degrees and push down through slot in A-pillar trim. (Fig. 1-3)
- c) After A-pillar trim is detached from connector, pull A-pillar firmly to detach lower clips.

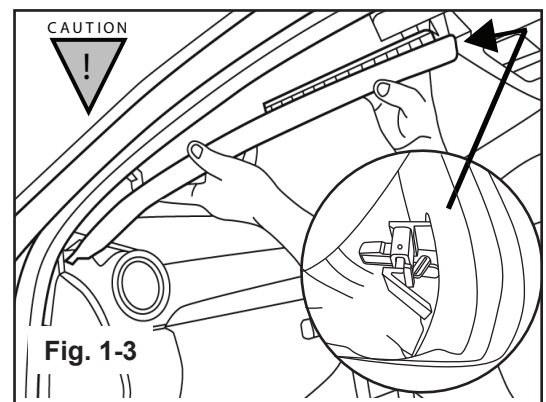

- d) Move the hook in the direction of arrows (1) and (2) using a Flat-head screwdriver and detach it from the A-pillar inner panel. (Fig. 1-4)
- e) Remove the grommet in the direction of the arrow (3). (Fig. 1-4)
- f) Install new supplied A-pillar tether clip into A-pillar before proceeding.

NOTE

A-pillar connector must be replaced with the supplied tether clip.

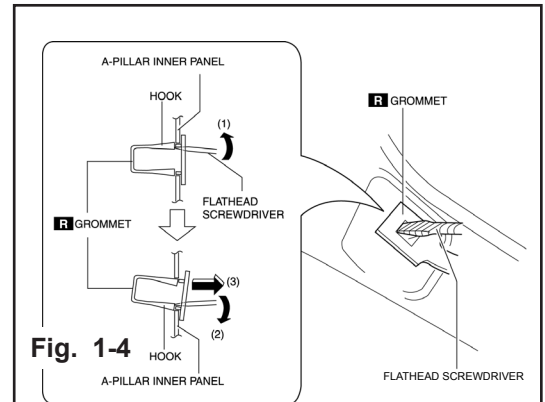

Fig. 1-4

6. Remove OE Mirror.

- a) Using a #T20 Torx, loosen the mirror mounting bracket screw. (Fig. 1-5)
- b) Grasp mirror mount at the tube, and gently pull upwards parallel to the windshield to carefully slide mirror off windshield button.

CAUTION

DO NOT rotate mirror, turn mirror side to side, or pull mirror away from the windshield. Rotation, side to side movement, or pulling of mirror on windshield button could damage or break the windshield and button, requiring windshield replacement.

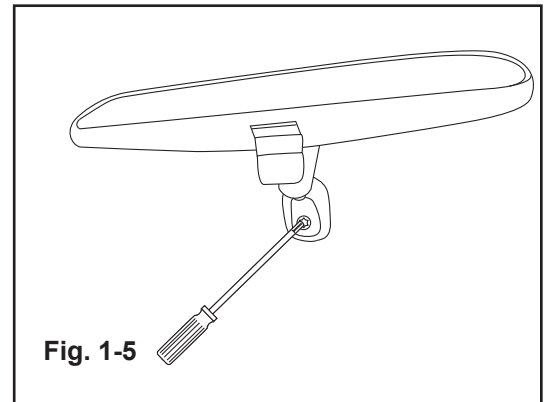

Fig. 1-5

2 EC Mirror Installation

1. Attach EC mirror.

- a) Hold the mirror head and slide the mount downwards as far as possible over the windshield button, until fully seated. (Fig. 2-1)
- b) Using a #T20 Torx, tighten the mirror mounting bracket screw to 15 lb-in.

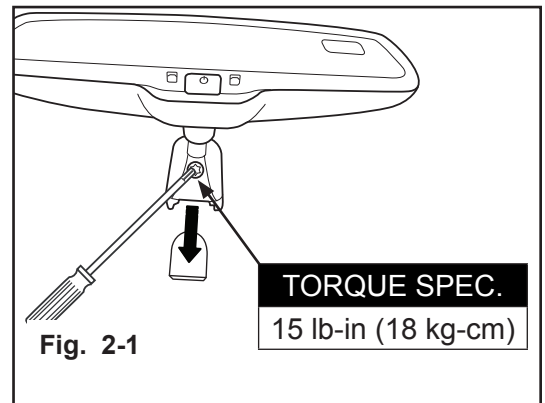

Fig. 2-1

TORQUE SPEC.
15 lb-in (18 kg-cm)

3 Route EC Harness to Vehicle Power

- 1. Plug EC harness connector into back of mirror. (Fig. 3-1)

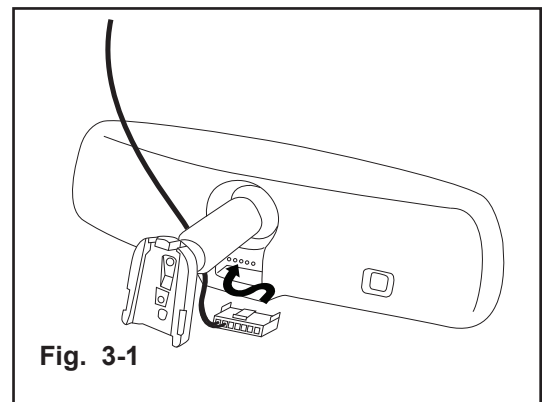
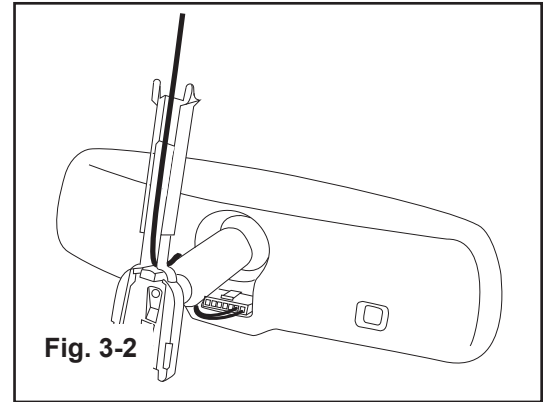

Fig. 3-1

2. Route EC harness from mirror to headliner.

- a) Route EC harness into groove of wire cover and attach wire cover to mirror base. **(Fig. 3-2)**

- (a) Slide upper portion of wire cover up to headliner so the "forks" are held by the headliner. **(Fig. 3-2)**



3. Route EC harness to driver-side A-pillar.

- a) Route EC harness between vehicle headliner and roof to top of driver-side A-pillar area. **(Fig. 3-3)**

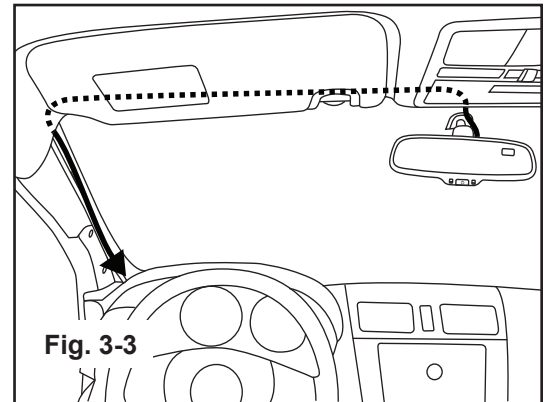

4. Route EC harness down driver-side A-pillar.

- a) Route EC harness down A-pillar and begin to secure to the top of the OE harness with (2) wire ties, as shown. **(Fig. 3-4)**

NOTE

See Wire Tie Procedure on Page 2 for detailed instructions and images of proper wire tie installation techniques.

CAUTION

Ensure EC harness does not interfere with airbag operation. Do not secure wire ties to air bag or sunroof drain tube.

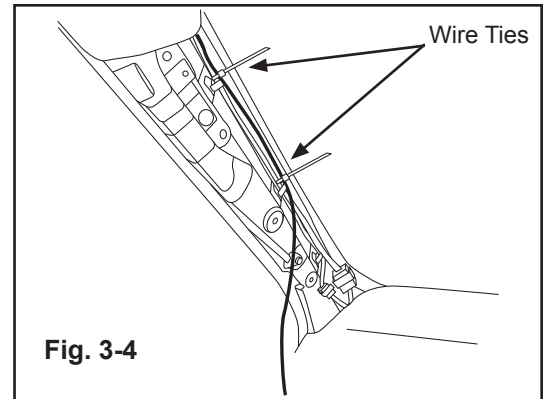

4 Connect EC Harness to Power and Ground

1. Connect the EC harness to the OEM connector .

- a) Locate the 12-pin connector in the driver-side A-pillar, as shown. **(Fig. 4-1)**

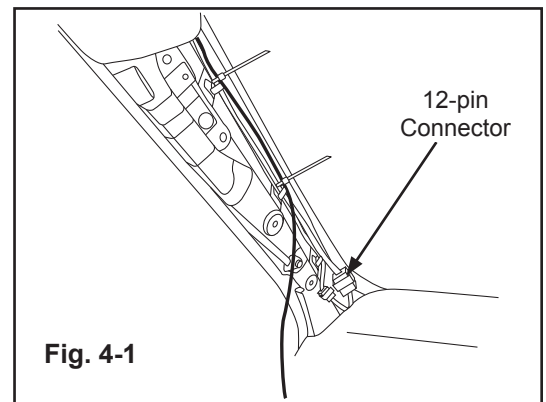

b) Disconnect the 12-pin connector. (Fig. 4-2)

NOTE



See **Disconnecting Connectors Procedure on Page 2** for detailed instructions and images of proper connector removal techniques.

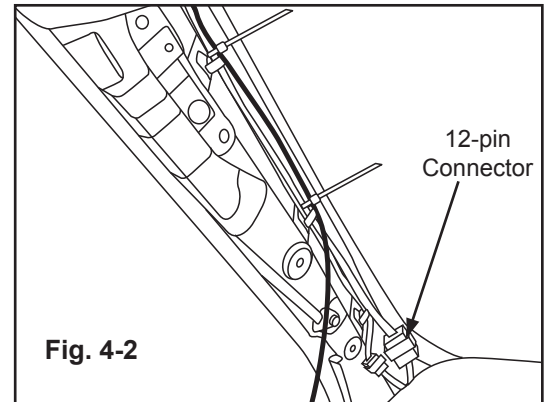

Fig. 4-2

c) Plug the male connector side of the EC harness into the lower OE connector and plug the female connector side of the EC harness into the upper portion of the OE harness. (Fig. 4-3)

NOTE



See **Locking Connectors Procedure on Page 2** for detailed instructions and images of proper connector installation techniques.

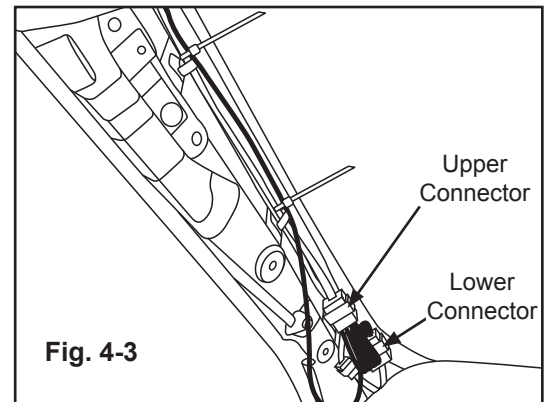

Fig. 4-3

5 Secure EC Harness.

1. Secure remaining EC harness in driver-side A-pillar.

a) Place (1) piece of foam tape on top of the small OE connector and the lower connector to prevent the EC harness from rattling. (Fig. 5-1)

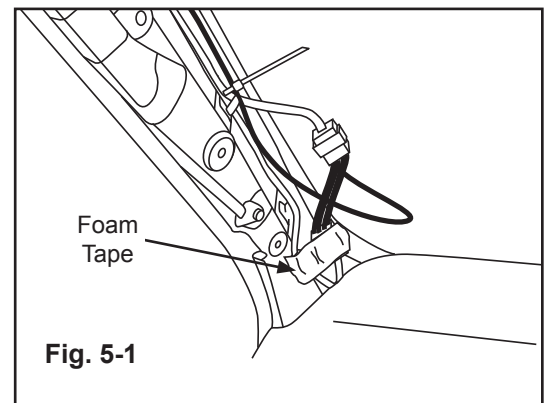

Fig. 5-1

b) Fold the Wires of the jumper harness down so that the upper connector rests on the foam tape. Bundle any remaining slack in EC harness near the OE connectors in the bottom of the A-pillar. Secure bundle and jumper harness to OE harness of smaller OE connector with (1) wire tie, as shown. (Fig. 5-2)

NOTE



See **Wire Tie Procedure on Page 2** for detailed instructions and images of proper wire tie installation techniques.

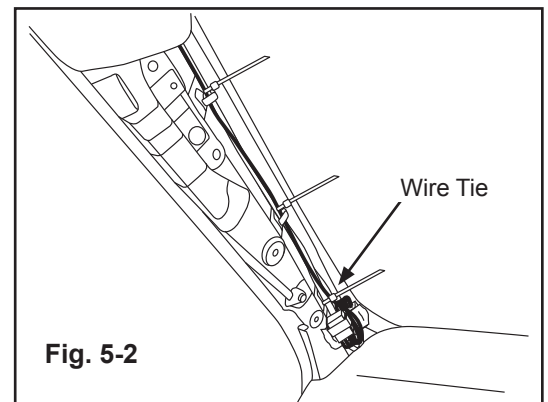

Fig. 5-2

CAUTION



Ensure EC harness does not interfere with airbag operation. Do not secure wire ties to air bag or sunroof drain tube.

6 Testing

1. Reconnect negative battery cable.
2. Turn the ignition switch to ON.
3. With the vehicle in a fairly well-lit area, perform the following:
 - a) To make sure the auto-dimming feature is on, verify that the green LED to the left of the center button is on. If it is not on, push the “☺” button to turn the green LED on.
 - b) Cover the forward looking photocell on the back of the mirror with a dark cloth or towel. (Fig. 6-1)
 - c) In a few seconds, the mirror will begin to darken.

NOTE

Time to darken will vary with ambient light level.

- d) Remove the cover from the forward looking photocell and the mirror will begin to clear.
- e) Verify that either a direction, such as NE, or “C” is displayed in the display window. If not, ensure the feature is turned ON by pressing the “☺” button.

4. Turn the ignition key to the OFF position.

NOTE

If compass remains on, refer to troubleshooting section and recheck proper wiring installation.

5. Testing is now complete.

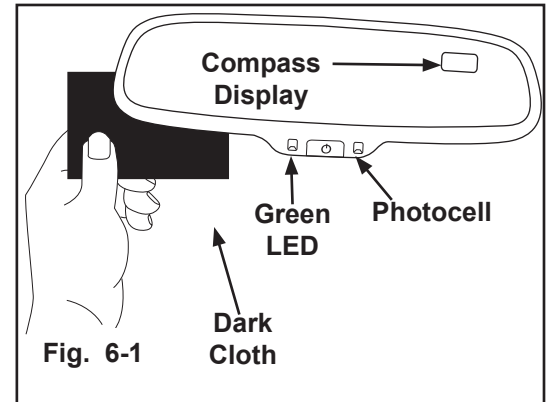

7 Installation of Removed Components

1. Trim excess off all tie wraps.
2. Reinstall in reverse order, all trim pieces removed during installation.
3. Place User Guide in vehicle glove-box. (Fig. 7-1)
4. Remove fingerprints, smudges, etc. from mirror.
5. Verify each reinstalled component for proper fit and function.

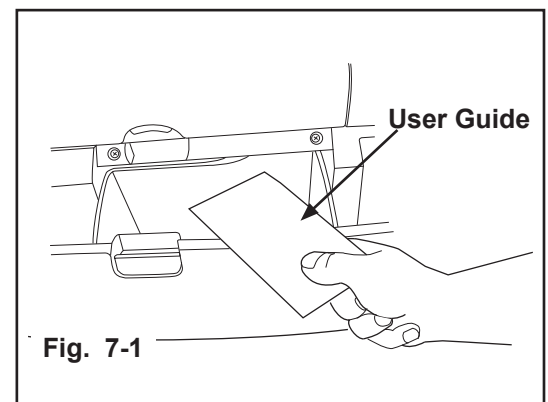

8 Compass Zone Adjustment (Dealer Install ONLY)

1. Adjust compass zone after EC mirror installation.

- a) The zone setting is factory preset to zone 8. Refer to Compass Calibration Zone Map (**Fig. 8-1**) to find the correct compass zone setting for your geographical location. Same map is in User Guide as well.
- b) To change the zone setting, push and hold the right, compass display button until a number appears in the display. Press button repeatedly until desired compass zone number is reached.

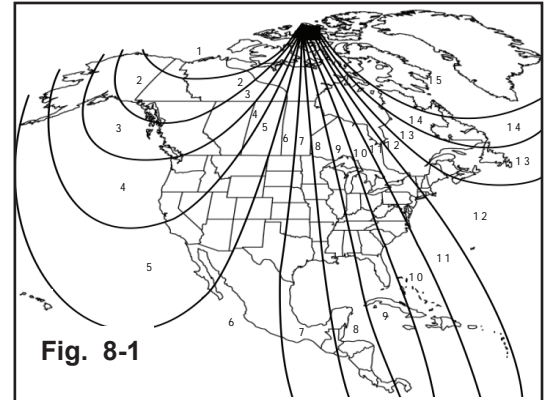

9 Compass Calibration (Dealer Install ONLY)

1. Calibrate compass.

- a) Drive to an open, level area, away from large metallic objects or structures.
- b) Hold the right, compass display button for approximately 9 seconds, until "C" test appears in the display. Release the right button to enter the calibration mode.
- c) Drive slowly in up to 3 circles until the "C" disappears and a directional heading is displayed. The compass is now calibrated.

10 Inspection

Inspection Parts	Inspection Items (O)			
	Clearance / Fit	Scratches / Dirt / Harness Interference	Installation / Tightening / Engagement	Operation Check
Negative battery terminal			O	
Driver-side Door Seal	O	O	O	
Driver-side A-pillar Trim	O	O	O	
EC mirror torx screw			*1 O	
EC harness connector	O	O	O	
EC mirror features:				
- Auto-dimming				*2 O
- Compass display				*3 O
User guide			*4 O	

O : Applicable

***1: Tightened to 15 lb-in (18 kg-cm)**

***2: Mirror dims (key must be in ON position).**

***3: Displays either "C" or directional heading (key must be in ON position).**

***4: In vehicle glove-box.**

CAUTION



When the battery is disconnected, the DSC may stop operating.

(The DSC OFF indicator will flash at this time, and the TCS/DSC operation indicator will illuminate.)

1. Turn the ignition switch to "OFF" and then turn it back to "ON".
2. Turn the steering wheel clockwise as far as it will go, and then turn it back counterclockwise as far as it will go.
3. Check that the TCS/DSC operation indicator is turned off.
4. Turn the ignition switch to "OFF" and then turn it back to "ON".
5. Check that the TCS/DSC operation indicator is turned off. If the TCS/DSC operation indicator is still illuminated or the DSC indicator is not turned off when the ignition switch is turned back to "ON", contact your Mazda dealer.

CAUTION



If the battery is disconnected, the power windows may no longer fully open or fully close automatically.

1. Turn the ignition key to the "ON" position.
2. Press the power window switch to fully open the power windows.
3. Lift up the power window switch to fully close the power windows, and keep it pulled up for approximately 2 seconds.
4. Position the engine switch at "OFF", and then at "ON" again. When the function doesn't work after these procedures, please contact your Mazda dealer.

CAUTION



If the battery is disconnected, the TPMS (Tire Pressure Monitoring System) initial setting is reset and the system may not operate normally.

1. Adjust the tire pressure (verify tire pressure using label on body side with driver's door open).
2. Turn the ignition switch to the "ON" position.
3. Press the TPMS (SET) switch (long-press it until TPMS warning light in meter flashes two times and a beep sounds one time).
4. Turn the ignition switch to "OFF."
5. If the TPMS warning light illuminates or flashes even though the above procedure has been performed, contact an Authorized Mazda Dealer.

BASIC INSTALLATION TROUBLE-SHOOTING

Verify the following:

1. B+ harness wire (pin 10 at the mirror connector) is receiving +12V with ignition OFF and ON.
2. Switched harness wire (pin 6 at the mirror connector) is receiving +12V with ignition ON and 0V with ignition OFF.
3. Ground wire (pin 3 at the mirror connector) is properly grounded.
4. EC harness is fully inserted into mirror.
5. Ensure jumper connectors are properly installed.
6. EC harness is not pinched, cut or damaged.

P1			
NO.	GAGE	COLOR	FUNCTION
1	20 AWG	BLACK	-
	22 AWG	BLUE	BATTERY
2	20 AWG	BLACK	-
3	20 AWG	BLACK	-
4	20 AWG	BLACK	-
5	20 AWG	BLACK	-
	22 AWG	RED	IGNITION
6	20 AWG	BLACK	-
7	20 AWG	BLACK	-
8	20 AWG	BLACK	-
9	20 AWG	BLACK	-
10	20 AWG	BLACK	-
11	20 AWG	BLACK	-
12	20 AWG	BLACK	-
	22 AWG	BLACK	GROUND

P2			
NO.	GAGE	COLOR	FUNCTION
1	20 AWG	BLACK	-
2	20 AWG	BLACK	-
3	20 AWG	BLACK	-
4	20 AWG	BLACK	-
5	20 AWG	BLACK	-
6	20 AWG	BLACK	-
7	20 AWG	BLACK	-
8	20 AWG	BLACK	-
9	20 AWG	BLACK	-
10	20 AWG	BLACK	-
11	20 AWG	BLACK	-
12	20 AWG	BLACK	-

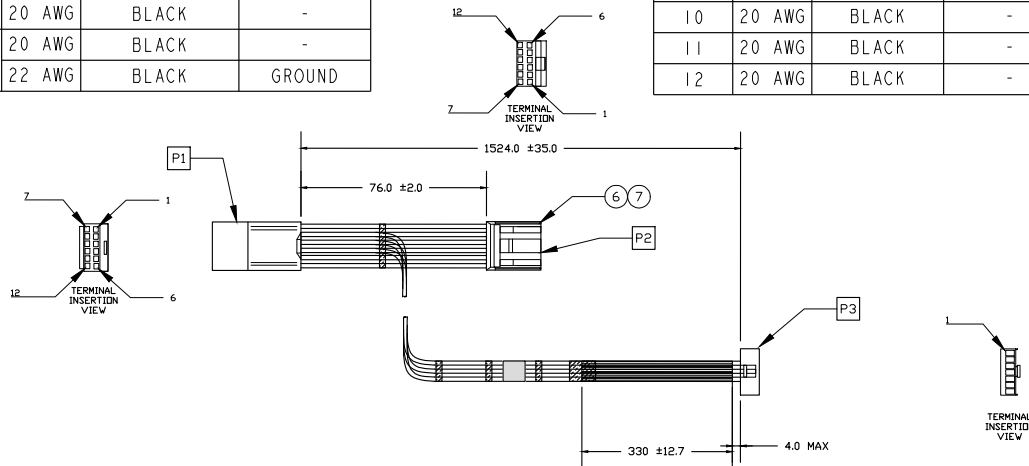

P3			
NO.	GAGE	COLOR	FUNCTION
1	22 AWG	RED	IGNITION
2	22 AWG	BLACK	GROUND
3			
4			
5			
6			
7			